

## TAMPING RAMMER



TAMPING RAMMER,  
Four-cycle Petrol Engine, 285mm foot

Model:MT-65H  
Product nos:51122, 51123, 51124, 51125

### SUITABLE APPLICATION

Most suitable for compacting cohesive and granular soils in narrow confined area

Most ideal for compacting trenches, backfills, asphalt patching work and others

### FEATURES and BENEFITS

\*Double-cleaner (main cleaner and pre-cleaner = Four filtration) trap airborne dirt and dust particles.

Pre-cleaner holds dirt and dust mostly and It reduces maintenance at main cleaner.

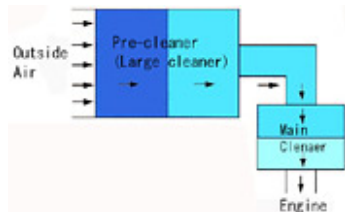

\*Mikasa original vertical Throttle Lever (Rack-and Pinion type) - easier to use and more durable

\*Impact Force is adjustable with variable Jumping stroke that can be set by throtte control.



\*Poly Fuel Tank - Corrosion Proof( High-density Polyethylene )



**Tough Bellows**

The rib (Honeycomb shape) strengthen the bellows to become durable against external shock. This is with patent.



**Option**

Convenient Lift Handle in loading the rammer

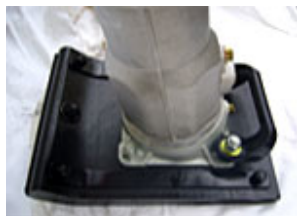

**SUITABLE APPLICATION**

(Features and specifications are subject to change without notification.)

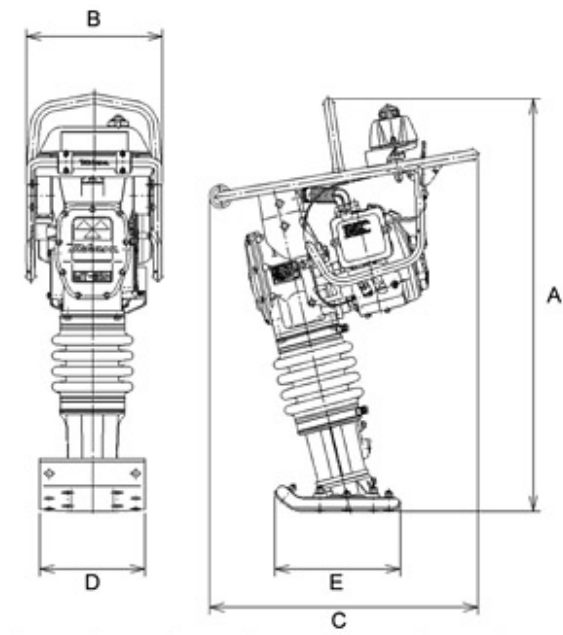

Dimensions (L x W X H)	A(HEIGHT) 1070	B(WIDTH) 370	C(LENGTH) 730	D 285	E 340
Operating Weight	<b>66kg</b>				
Jumping Stroke	50-80 mm				

Impact Force	12.7 kN 1,300 kgf
Impact Number per min.	644 -695
Fuel Capacity	2.0 liters
Engine Type	Air-cooled, 4 cycle, Petrol(Gasoline)
Model	Honda GX100
Max. output	2.1 kW (2.9PS)

Impact Force is measured at Mikasa in comply with CIMA-LEMB  
Weight is measured in comply with Directive EN500-4

---

[TOP](#)

Copyrights 2008 MIKASA SANGYO CO.,LTD All Rights Reserved.